

TREE OF LIGHT

TOL_CHN_23V1

ILANEL



Nine hand-blown glass spheres are suspended from tiered branches that radiate out from its centre. The trunk is made from individual brass tubes, and the hand-blown glass spheres congregate like a cloud of floret.

TREE OF LIGHT

TOL_CHN_23V1

ILANEL

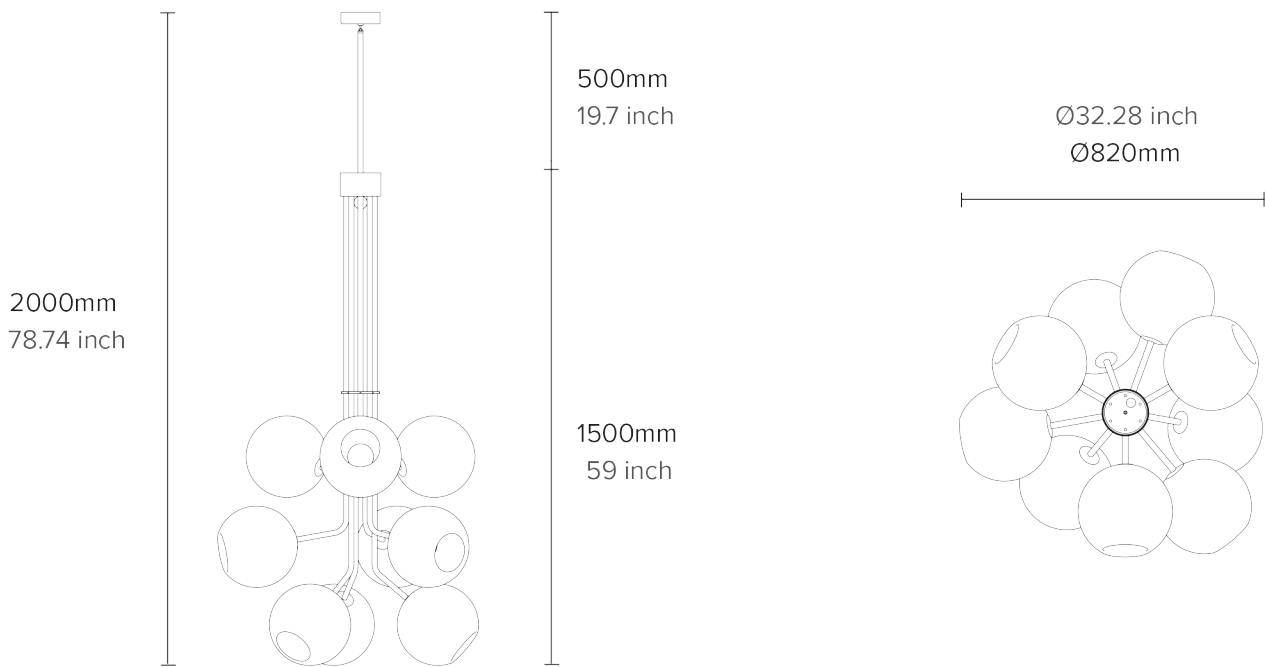

TYPE

Chandelier

MATERIAL

Brass, Mild Steel, Hand-blown Glass

WEIGHT

37.0kg

MODEL

TOL-09

TOL-06

TOL-03

LIGHT SOURCE

E27, Max 10W

Light bulb not supplied unless requested

CERTIFICATION

ETL/UL upon request for North America

DIMENSION

Ø820mm x 1500mm

Glass Sphere: Ø250mm

SUSPENSION

2m Rod Suspension or Ceiling Mounted

Custom lengths upon request

WARRANTY

3 years residential

2 years commercial

DROP LENGTH

Standard 2m

Custom lengths upon request

TREE OF LIGHT

TOL_CHN_23V1

ILANEL

METAL FINISHES



AGED
Brass



BLACK ACE
Powdercoat



CUSTOM



SATIN WHITE
Powdercoat

GLASS FINISHES



CLOUDY WHITE

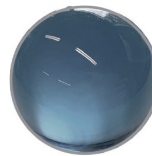

NAVY



EMERALD



FROSTED NAVY

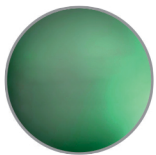

FROSTED EMERALD



TEAL



AMBER



FROSTED TEAL



FROSTED AMBER



SMOKE

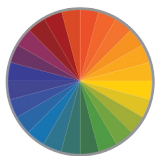

CUSTOM

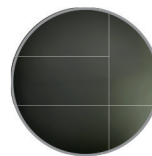

FROSTED SMOKE